



Integrated Encoder

User Manual

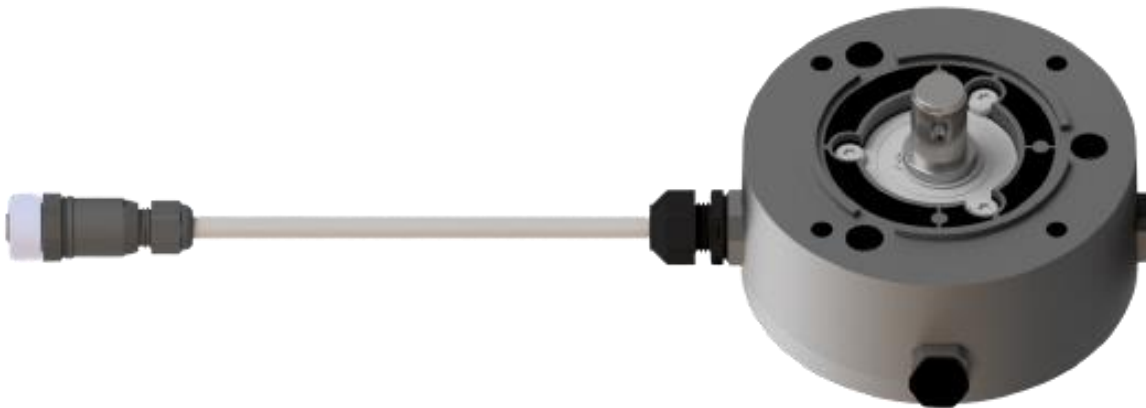

Table of Contents

1	Device Overview	4
1.1	Basic Interface Diagram	4
1.2	Product and Operating Characteristics	5
2	Installation	6
2.1	Mounting	7
2.2	Wiring	11
3	LEDs.....	12
4	Operation.....	12
5	Battery	13
6	Technical Assistance	14

CONVENTIONS USED THROUGHOUT THIS MANUAL

WARNING	Items with this label must be carefully considered to avoid any damage to system components.
NOTE	Items with this label should be considered for best results.

1 Device Overview

The BTR Integrated Encoder is designed to operate with an industrial door operator and controller to provide absolute positioning and motor displacement information. The thru-shaft design provides a compact, rugged, and consistent solution that can be factory installed and easily retrofitted in the field.

- Custom molded housing for seamless fit to operator
- Replaceable 3.6V battery
- Self-Contained unit (no need for external magnets, adapters, etc...)
- Design for heavy industrial and noisy electrical environments
- Terminal blocks provided for easy connection (or factory M12 cable option)
- Power and Status LED indication for troubleshooting

1.1 Basic Interface Diagram

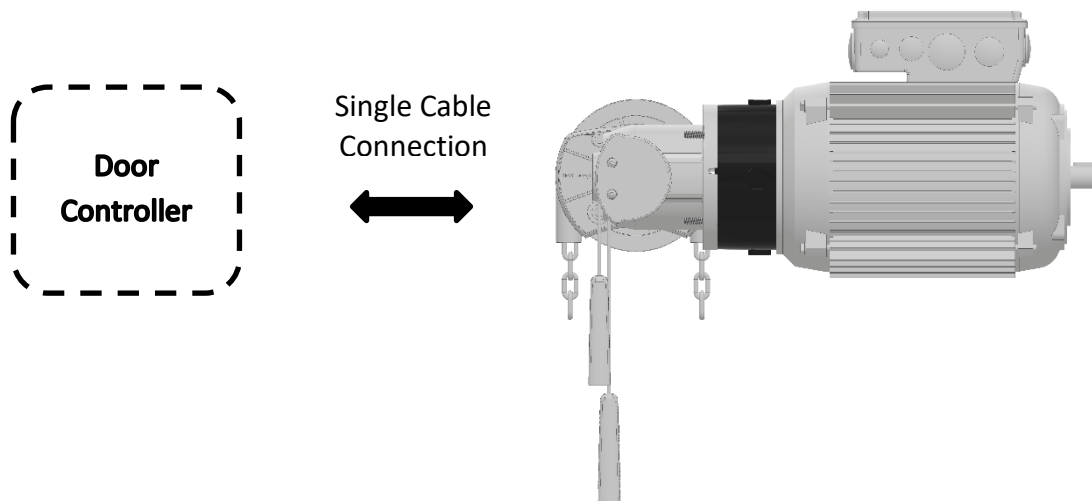

1.2 Product and Operating Characteristics

Standard Operating Conditions (unless otherwise stated)				
Characteristic	Min	Typical	Max	Units
Supply Voltage	9.0	12	30	VDC
Operating Current		45		mA
Readout Rate	5	10		ms
Maximum Turns ¹			> 1.7 x 10 ⁸	
Resolution			15	Degree
Pulse Output Voltage		Supply – 1.0		VDC
Pulse Output Current			100	mA
Battery Life ²			5	Years
Max Speed Powered			4000	RPM
Max Speed Unpowered			250	RPM
Weight		19.2 (545)		Ounces (Grams)

¹ After maximum turns is reached, the internal count rolls over to zero

² Life determined for duty cycle of 16 hours ON and 8 hours OFF per day

Environmental Specifications	
Operating Temperature	-40°F to 185°F (-40°C to 85°C)
Ingress Protection	IP53

WARNING	Operating the encoder outside of these specified limits may cause damage and will VOID the Warranty.
----------------	--

2 Installation

This section covers the Integrated Encoder installation.

WARNING

POWER TO THE OPERATOR MUST BE DISCONNECTED BEFORE INSTALLATION!

- Section 2.1 Mounting
- Section 2.2 Wiring

NOTE

Ensure the battery is connected before mounting the encoder to the operator.

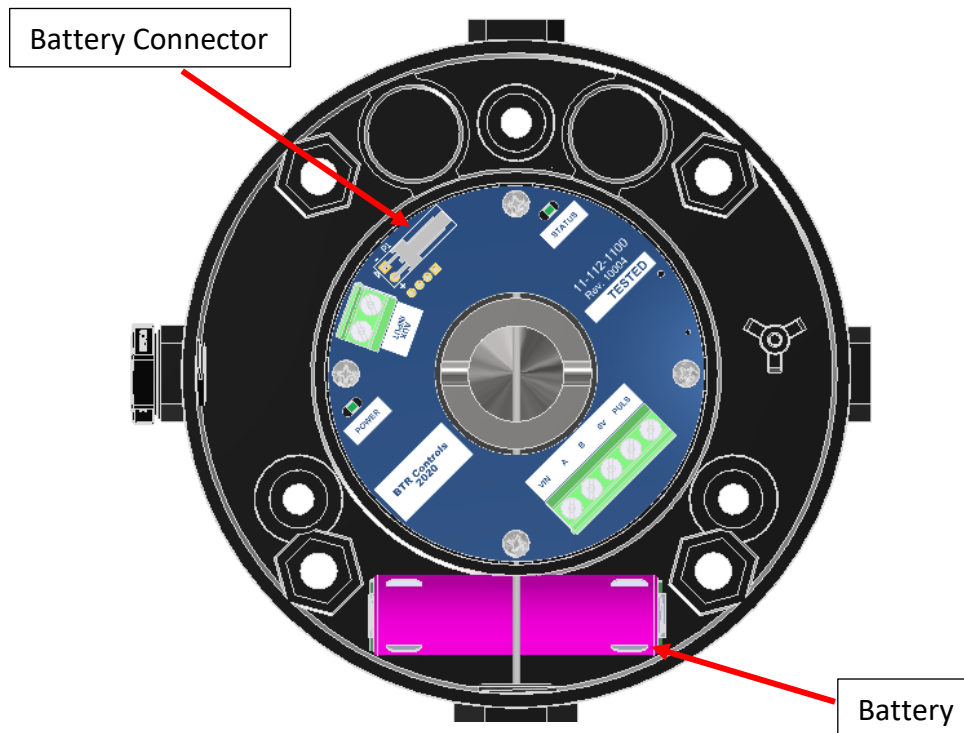

2.1 Mounting

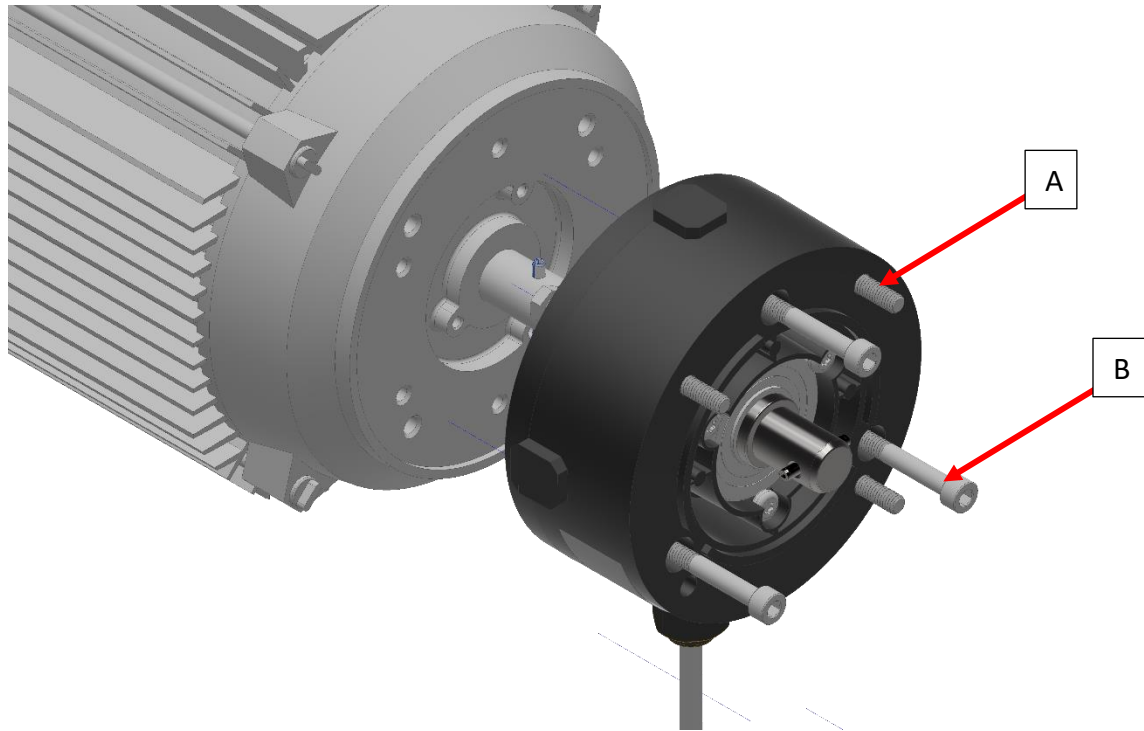

The Integrated encoder was designed to mount to the SI line of operators from GfA Elektromaten. Consult with BTR Controls on compatible operators.

Recommended Hardware		
Reference	Description	Qty
A	Bolt, M6 x 1mm Thread, 70mm Long	3
B	Screw, M5 48mm Long, Thread Forming Taptite II	3
C	Nut, M6 Flanged	3

NOTE	Ensure bolts (A) noted above are installed into the encoder before attaching to a motor.
-------------	--

1. Align encoder with the cable facing away from the motor junction box
2. Align encoder shaft with pin from the motor
3. Insert encoder over motor shaft until housing meets motor

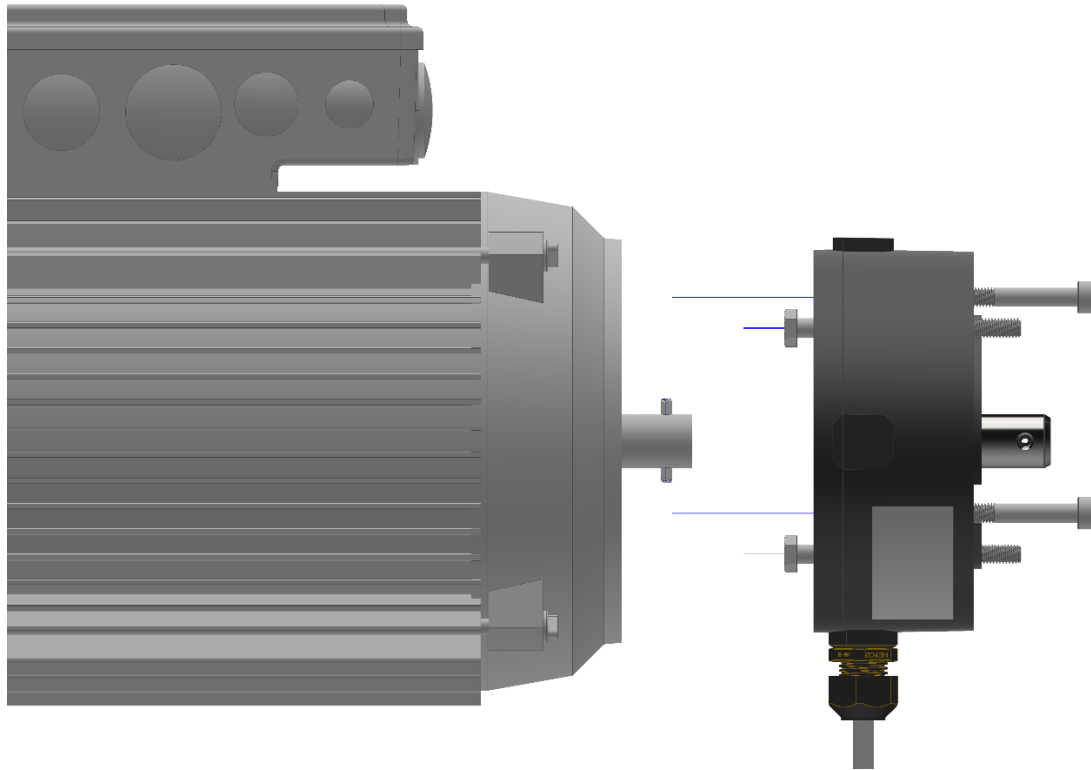

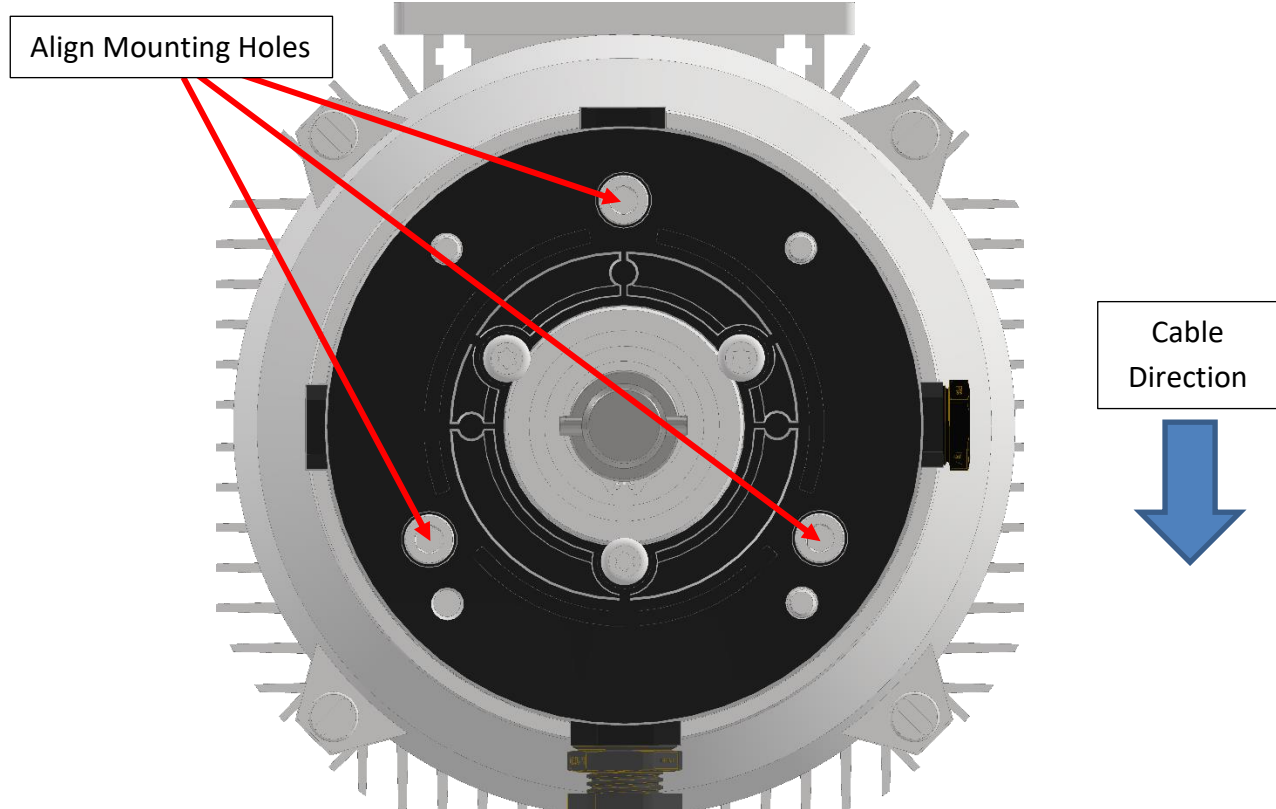

4. Rotate encoder to align mounting holes
5. Using screws (B) from above, attach encoder to motor
 - a. Torque 5 ft-lb

WARNING

Damage to the housing can occur if excessive torque is applied during mounting!

6. Align Chain Hoist mechanism with encoder
7. Insert Chain Hoist over the 3 mounting bolts (A)

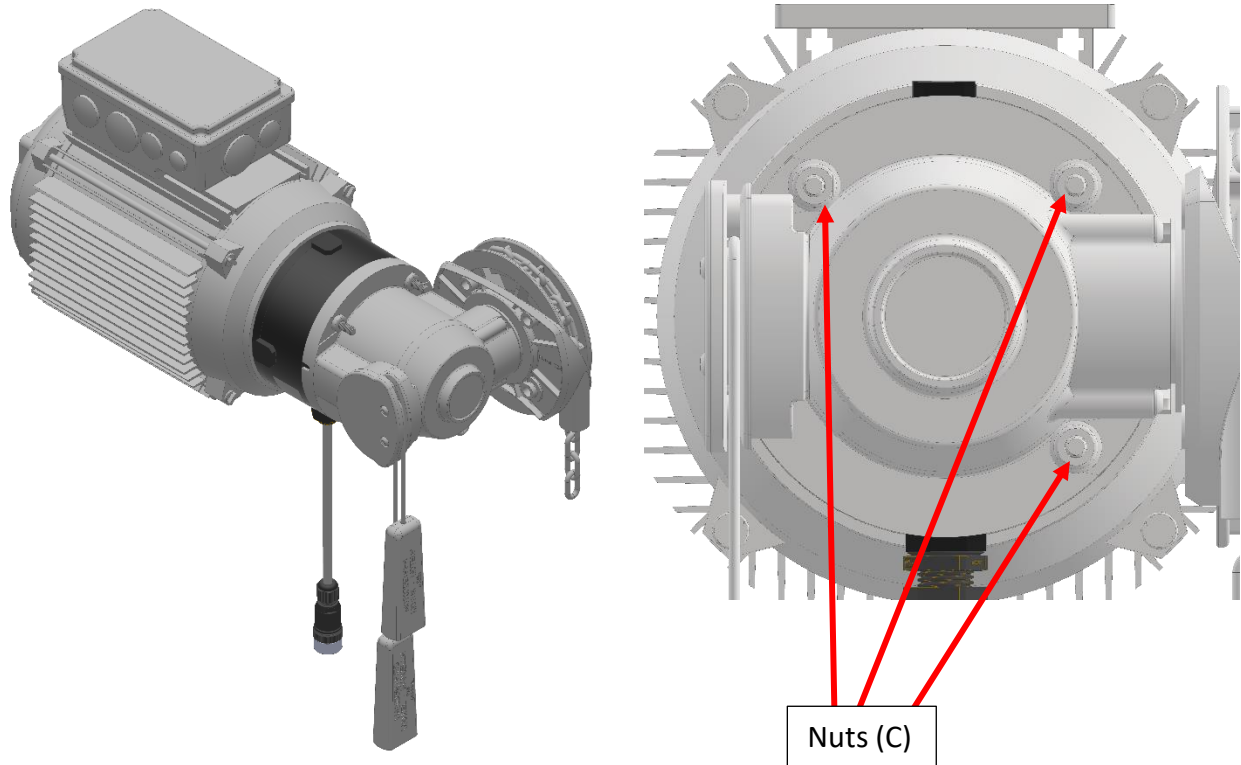

8. Install nuts (C) on mounting bolts and tighten Chain Hoist mechanism
 - a. Torque 8 ft-lb

NOTE	Check installation with Chain Hoist mechanism. Assembly should rotate freely.
-------------	---

2.2 Wiring

Wiring	
Wire Color	Description
BROWN	+V
GRAY	RS485 A
WHITE	RS485 B
BLUE	0V
BLACK	Pulse Output
Shield/Drain	Earth Ground

NOTE

- Only the recommended cable provided by BTR Controls should be used
- The cable must not be cut or spliced in any form
- Ensure the shield and drain are properly grounded

1. Connect an extension cable to the M12 connector on the encoder.
 - a. Ensure the metal coupling nut is fully engaged
2. Connect the extension cable to a corresponding door controller according to the wiring table above.

WARNING

The encoder is not intended for use on a multi-drop RS485 network.

3 LEDs

The encoder is equipped with two board mounted LEDs.

- Power LED – This LED will be ON when external power is applied
- Status LED – This LED will flash when the encoder detects rotation of the shaft to signal a change in position.

4 Operation

The encoder operates in 2 modes **NORMAL** and **UNPOWERED** and will automatically select the appropriate mode.

NORMAL MODE

- External power is present
- Communication with the encoder is enabled
- Pulse output signal is enabled
- The angular velocity and acceleration of the encoder shaft are unrestricted

UNPOWERED MODE

- External power to the encoder has been removed.
- Communication with the encoder and the pulse output signal is halted.
- The angular velocity and acceleration of the encoder shaft is REDUCED

5 Battery

The encoder includes a user replaceable battery. The battery is necessary to maintain absolute positioning when external power is not present. Refer to the installation section of this manual for disassembly instructions.

NOTE	EXACT battery must be used for replacement!
-------------	--

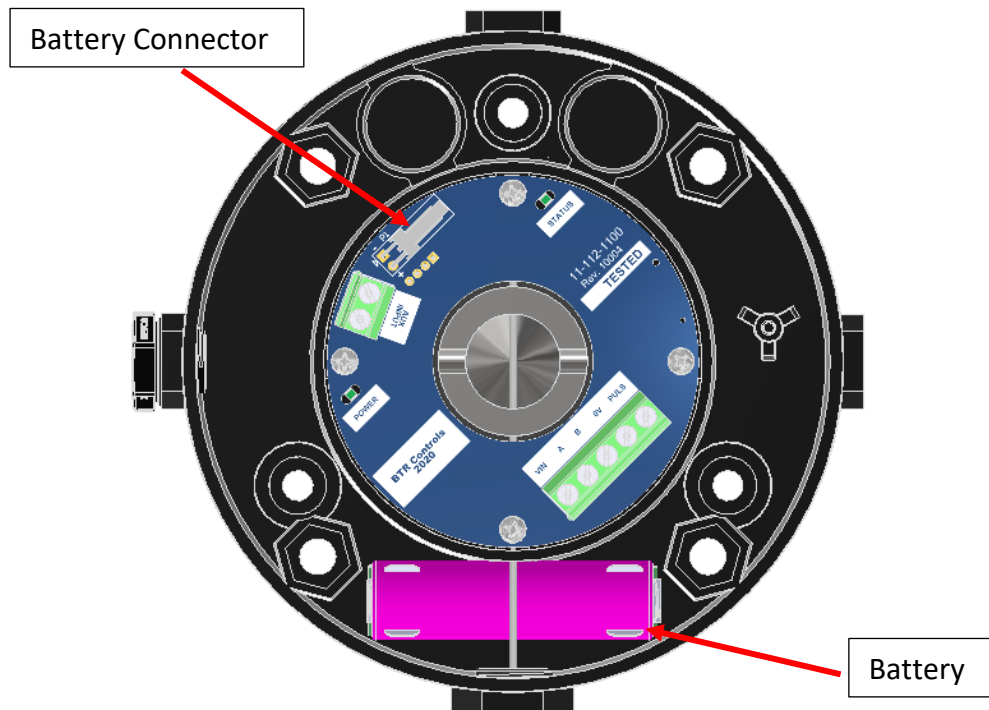

NOTE	The internal position will be reset if the battery is removed
-------------	---

6 Technical Assistance

Contact:

BTR Controls, Inc.
1570 Todd Farm Dr.
Elgin, IL 60123
(847)608-9500